

THE HOME OF INNOVATION.

*Eltako*



# ENERGY METERS. SINGLE AND THREE PHASE WITH OR WITHOUT MID APPROVAL.

INTELLIGENTLY MEASURE AND VISUALIZE POWER

**PRODUCTS AND PRICES 2022**

*Eltako*

PROFESSIONAL  
**STAN  
DARD**







# Three-phase and single-phase energy meters

Selection table three-phase meters and single-phase energy meters	4
Three-phase meter <a href="#">DSZ15D-3x80A MID</a>	5
Three-phase meter <a href="#">DSZ15DE-3x80A</a> , without MID approval	6
CT operated three-phase energy meter <a href="#">DSZ15WD-3x5A MID</a>	7
M-bus three-phase energy meter <a href="#">DSZ15DM-3x80A MID</a>	8
M-bus CT operated three-phase energy meter <a href="#">DSZ15WDM-3x5A MID</a>	9
RS485 bus wireless three-phase energy meter <a href="#">DSZ14DRS-3x80A MID</a>	10
RS485 bus wireless three-phase energy meter <a href="#">DSZ14WDRS-3x5A MID</a>	11
RS485 bus wireless single-phase energy meter <a href="#">FWZ14-65A</a>	12
RS485 bus meter collector <a href="#">F3Z14D</a>	13
RS485 bus energy meter data gateway <a href="#">FSDG14</a>	14
Single-phase energy meter <a href="#">WSZ15D-32A MID</a>	15
Single-phase energy meter <a href="#">WSZ15DE-32A</a> , without MID approval	15
Single-phase energy meter <a href="#">WSZ15D-65A MID</a>	16
Single-phase energy meter <a href="#">WZR12-32A</a> with reset, without MID approval	17
<b>NEW</b> Mobile single-phase energy meter <a href="#">WSZ110DSS-16A MID</a>	18
<b>NEW</b> Mobile single-phase energy meter <a href="#">WSZ110DSS-16A+PRCD MID</a>	19
<b>NEW</b> Mobile single-phase energy meter <a href="#">WSZ110CEE-16A MID</a>	19
<b>NEW</b> Mobile single-phase energy meter <a href="#">WSZ110CEE-16A+PRCD MID</a>	20
<b>NEW</b> Mobile three-phase energy meter <a href="#">DSZ180CEE-32A MID</a>	20
Wireless Visualisation and Control Software <a href="#">GFVS-Energy</a>	21
Wireless energy meter transmitter module <a href="#">FSS12-12V DC</a>	21
Direct display with the wireless energy consumption indicator <a href="#">FEA65D-wg</a>	22
Single-phase energy meter with energy consumption indicator <a href="#">EVA12-32A</a>	23
Wireless single-phase energy meter <a href="#">FWZ12-65A</a>	24
Wireless actuator impulse switch with integr. relay function <a href="#">FSR61VA-10A</a> with current measurement	25
Socket switching actuator <a href="#">FSVA-230V-10A</a> with current measurement	25
Technical data single-phase energy meter, three-phase energy meters and energy consumption indicator	26
Measuring Instruments Directive MID	27
Installation instructions for electricians	28

## SELECTION TABLE THREE-PHASE AND SINGLE-PHASE ENERGY METERS

# THE SMART COUNTING CHAMPIONS

Depending on the customer's installation, only a conventional meter panel is required for billing with the electricity supply operator. On the other hand, dwellings and businesses can be billed using small three-phase meters installed in power distribution panels. See the installation instructions for electricians on page 25. It is then the task of the building management service to read

the intermediate meter. This either takes place at the same time as heating consumption is read or centrally, e.g. when the meter interface is evaluated. All Eltako energy meters for rail mounting are therefore fitted as standard with an S0 interface.

Page	10-3	10-4	10-5	10-6	10-7	10-8	10-9	10-13	10-13	10-14	10-15	10-16	10-17	10-18
	DSZ15D-3x80A	DSZ15DE-3x80A	DSZ15WD-3x5A	DSZ15DM-3x80A	DSZ15WDM-3x5A	DSZ14DRS-3x80A	DSZ14WDRS-3x5A	WSZ15D-32A	WSZ15DE-32A	WSZ15D-65A	WZR12-32A	WSZ110DSS-16A	WSZ110CEE-16A	DSZ180CEE-32A
Modular device for mounting on DIN rail EN 60715 TH35, number of modules 18 mm each	4	4	4	4	4	4	4	1	1	1	1			
mobil												■	■	■
Single-phase energy meter								■	■	■	■	■	■	
Three-phase energy meter	■	■	■	■	■	■	■							■
With MID approval	■		■	■	■	■	■	■		■		■	■	■
Reference current $I_{ref}$ (Limiting current $I_{max}$ ) A	10(80)	10(80)	5(6) <sup>1)</sup>	10(80)	5(6) <sup>1)</sup>	10(80)	5(6) <sup>1)</sup>	5(32)	5(32)	10(65)	5(32)	5(32) lb=16	5(32) lb=16	10(80) lb=32
Display LC display digits	5+2 <sup>2)</sup> 6+1	5+2 <sup>2)</sup> 6+1	6+1	5+2 <sup>2)</sup> 6+1	6+1	5+2 <sup>2)</sup> 6+1	6+1	5+2 <sup>2)</sup> 6+1	5+2 <sup>2)</sup> 6+1	5+2 <sup>2)</sup> 6+1	2/4	5+2 <sup>2)</sup> 6+1	5+2 <sup>2)</sup> 6+1	5+2 <sup>2)</sup> 6+1
Accuracy class MID, inaccuracy ±1%	B	B	B	B	B	B	B	B	B	B	B	B	B	B
With return stop	■	■	■	■	■	■	■	■	■	■	■	■	■	■
Display instantaneous values	■	■	■	■	■	■	■	■	■	■	■	■	■	
Indication of misconnection	■	■	■	■	■	■	■	■	■	■	■			
Low standby loss	■	■	■	■	■	■	■	■	■	■	■	■	■	■
S0 interface potential	■	■	■					■	■	■				
M-bus interface				■	■									
Interface for Eltako RS485 bus						■	■							

<sup>1)</sup> CT operated energy meter

<sup>2)</sup> Switches over automatically from 5+2 to 6+1.

**MID meters require no subsequent calibration with calibration mark. Instead, they are the equivalent of calibrated meters as a result of MID testing and an EU Declaration of Conformity from the manufacturer.**



## DSZ15D-3X80A MID

MID

**Maximum current 3x80 A. Standby loss 0.5 watt per path only.**

Modular device for DIN-EN 60715 TH35 rail mounting.

4 modules = 70 mm wide and 58 mm deep.

Accuracy class B (1%). With SO interface.

It measures active energy by means of the current between input and output. The internal power consumption of 0.5 watt active power per path is neither metered nor indicated.

1, 2 or 3 phase conductors with max. currents up to 80 A can be connected.

The inrush current is 40 mA.

The N terminal must always be connected.

**The 7 segment LC display is also legible twice within a period of 2 weeks without power supply.**

Power consumption is shown by a bar flashing at a rate of 100 times per kWh.

**Designed as standard for using as double-tariff meter:** Switch over to a second tariff by applying 230 V to terminals E1/E2.

On the right next to the display are the keys MODE and SELECT. Press them to scroll through the menu according to the operation manual. First the **background lighting** switches on. The display then shows the total active energy per tariff, the active energy per resettable memory RS1 or RS2, and the instantaneous values of consumption, voltage and current per phase.

### Error message (false)

When the phase conductor is missing or the current direction is wrong 'false' and the corresponding phase conductor are indicated on the display.

### Typical connection

4-wire-connection 3x230/400 V

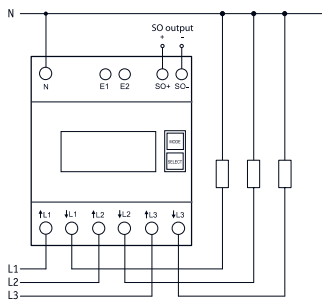

Technical data page 26.

<b>DSZ15D-3x80A</b>	Three-phase energy meter, MID approval	EAN 4010312501634	<b>133,60 €/pc.</b>
---------------------	--	-------------------	---------------------

## THREE-PHASE ENERGY METER DSZ15DE-3X80A, WITHOUT APPROVAL



### Typical connection

4-wire-connection 3x230/400 V

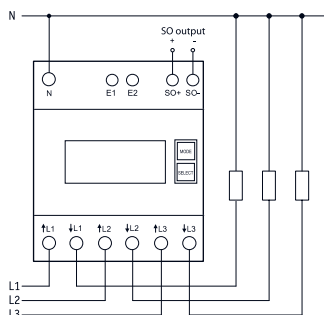

Technical data page 26.

## DSZ15DE-3X80A

**Maximum current 3x80 A. Standby loss 0.5 watt per path only.**

Modular device for DIN-EN 60715 TH35 rail mounting.

4 modules = 70 mm wide and 58 mm deep.

Accuracy class B (1%). With SO interface.

It measures active energy by means of the current between input and output. The internal power consumption of 0.5 watt active power per path is neither metered nor indicated. Like all meters without declaration of conformity (e.g. MID), this meter is not permitted for billing.

1, 2 or 3 phase conductors with max. currents up to 80 A can be connected.

The inrush current is 40 mA.

The N terminal must always be connected.

**The 7 segment LC display is also legible twice within a period of 2 weeks without power supply.**

Power consumption is shown by a bar flashing at a rate of 100 times per kWh.

**Designed as standard for using as double-tariff meter:** Switch over to a second tariff by applying 230 V to terminals E1/E2.

On the right next to the display are the keys MODE and SELECT. Press them to scroll through the menu according to the operation manual. First the **background lighting** switches on. The display then shows the total active energy per tariff, the active energy per resettable memory RS1 or RS2, and the instantaneous values of consumption, voltage and current per phase.

### Error message (false)

When the phase conductor is missing or the current direction is wrong 'false' and the corresponding phase conductor are indicated on the display.

<b>DSZ15DE-3x80A</b>	Three-phase energy meter, without approval	EAN 4010312501719	<b>93,80 €/pc.</b>
----------------------	--	-------------------	--------------------



## DSZ15WD-3X5A MID

MID

**CT operated three-phase energy meter with settable CT ratio and MID. Maximum current 3x5 A. Standby loss 0.5 watt per path only.**

Modular device for DIN-EN 60715 TH35 rail mounting.  
4 modules = 70 mm wide and 58 mm deep.  
Accuracy class B (1%). With SO interface.

This three-phase energy meter measures active energy by means of the current between input and output. The internal power consumption of 0.5 watt active power per path is neither metered nor indicated.

**1, 2 or 3 phase conductors with max. currents up to 5 A can be connected.**

The inrush current is 10 mA.

The N terminal must always be connected.

**The 7 segment LC display is also legible twice within a period of 2 weeks without power supply.**

Power consumption is shown by a bar flashing at a rate of 10 times per kWh.

On the right next to the display are the keys MODE and SELECT. Press them to scroll through the menu according to the operation manual. First the **background lighting** switches on. The display then shows the total active energy, the active energy per resettable memory, and the instantaneous values of consumption, voltage and current per phase.

**The CT ratio can also be set.** It is set to 5:5 at the factory and blocked with a bridge over the terminals which are marked with 'JUMPER'. To adjust the CT ratio to the installed transformer remove the bridge and reset the energy meter according to the operation manual. Then block it again with the bridge. Adjustable current transformer ratios: 5:5, 50:5, 100:5, 150:5, 200:5, 250:5, 300:5, 400:5, 500:5, 600:5, 750:5, 1000:5, 1250:5 and 1500:5.

**Error message (false)**

When the phase conductor is missing or the current direction is wrong 'false' and the corresponding phase conductor are indicated on the display.

**Important!** Before working on the current transformers disconnect the voltage paths of the energy meters.

### Typical connection

4-wire-connection 3x230/400 V

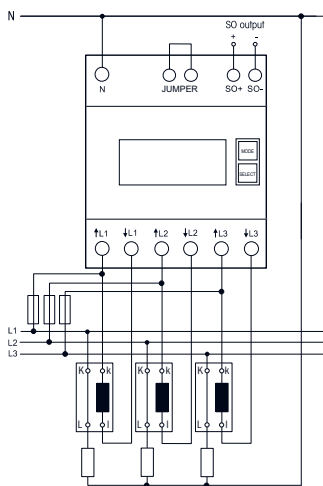

Technical data page 26.

<b>DSZ15WD-3x5A</b>	CT operated three-phase energy meter, MID approval	EAN 4010312501641	<b>182,50 €/pc.</b>
---------------------	--	-------------------	---------------------



## DSZ15DM-3X80A MID

MID

### Typical connection

4-wire-connection 3x230/400 V

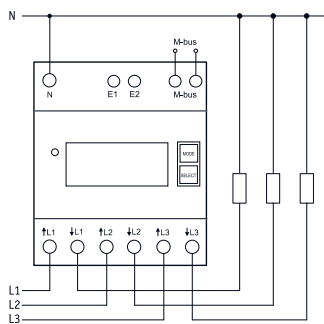

### M-bus three-phase energy meter.

**Maximum current 3x80 A. Standby loss 0.5 watt per path only.**

Modular device for DIN-EN 60715 TH35 rail mounting.

4 modules = 70 mm wide and 58 mm deep.

Accuracy class B (1%). With M-bus interface.

It measures active energy by means of the current between input and output.

The internal power consumption of 0.5 watt active power per path is neither metered nor indicated.

**1, 2 or 3 phase conductors with max. currents up to 80 A can be connected.**

The inrush current is 40 mA.

The N terminal must always be connected.

**The 7 segment LC display is also legible twice within a period of 2 weeks without power supply.**

Power consumption is indicated by an LED flashing at a rate of 1000 times per kWh.

**Designed as standard for using as double-tariff meter:** Switch over to a second tariff by applying 230 V to terminals E1/E2.

On the right next to the display are the keys MODE and SELECT. Press them to scroll through the menu.

First the **background lighting** switches on. The display then shows the total active energy per tariff, the active energy of the resettable memory RS1 or RS2 as well as the instantaneous values of consumption, voltage and current per phase

### Error message (false)

When the phase conductor is missing or the current direction is wrong 'false' and the corresponding phase conductor are indicated on the display.

### M-bus data transfer

- On read-out all values are transferred in a telegram.

- The following telegrams are supported:

- Initialisation: SND\_NKE Reply: ACK
- Read out meter: REQ\_UD2 Reply: RSP\_UD
- Change primary address: SND\_UD Reply: ACK
- Reset RS1: SND\_UD Reply: ACK
- Slave selection for the secondary address Reply: ACK

- The device does not reply to unknown requests

- The transfer rate is detected automatically

- The device has a voltage monitor. In case of voltage loss, all registers are saved in the EEPROM.

### Changing the M-bus primary address:

To change the M-bus primary address, hold down SELECT for 3 s. In the menu that appears, press MODE to increment the address by 10. Press SELECT to increment by 1. When the required primary address is set, wait until the main menu reappears.

### Secondary address

- It is possible to communicate with the energy meters according to the standard EN13757 using the secondary address.

- The use of wild cards is possible.

For details refer to the operating instructions at [www.eltako.com](http://www.eltako.com).

Technical data page 26.

<b>DSZ15DM-3x80A</b>	M-bus three-phase energy meter, MID approval	EAN 4010312501726	<b>217,90 €/pc.</b>
----------------------	--	-------------------	---------------------





## DSZ15WDM-3X5A MID

MID

### Typical connection

4-wire-connection 3x230/400 V

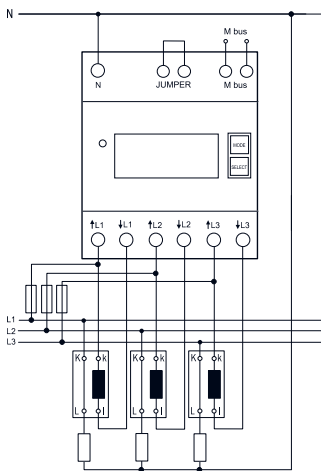

**M-bus CT operated three-phase energy meter with settable CT ratio and MID. Maximum current 3x5 A. Standby loss 0.5 watt per path only.**

Modular device for DIN-EN 60715 TH35 rail mounting.

4 modules = 70 mm wide and 58 mm deep.

Accuracy class B (1%). With M-bus interface.

This three-phase meter measures active energy by means of the currents flowing between inputs and outputs. The internal power consumption of 0.5 watt active power per path is neither metered nor indicated.

**1, 2 or 3 converters with secondary currents of up to 5 A can be connected.**

The inrush current is 10 mA.

The N terminal must always be connected.

**The 7 segment LC display is also legible twice within a period of 2 weeks without power supply.**

Power consumption is indicated by an LED flashing at a rate of 10 times per kWh.

On the right next to the display are the MODE and SELECT buttons to browse through the menu. First the **background lighting** switches on. Then the total active energy, the active energy of the resettable memory and the instantaneous values of power, voltage and current are displayed for each outer conductor.

**The CT ratio can also be set.** It is set to 5:5 at the factory and blocked with a bridge over the terminals which are marked with 'JUMPER'. To adjust the CT ratio to the installed transformer remove the bridge and reset the energy meter according to the operation manual. Then block it again with the bridge. Adjustable current transformer ratios: 5:5, 50:5, 100:5, 150:5, 200:5, 250:5, 300:5, 400:5, 500:5, 600:5, 750:5, 1000:5, 1250:5 and 1500:5.

### Error message (false)

If there is no outer conductor of the current direction is incorrect, 'false' and the related outer conductor are indicated in the display.

### M-bus data transfer

- On read-out all values are transferred in a telegram.

- The following telegrams are supported:

- Initialisation: SND\_NKE Reply: ACK
- Read out meter: REQ\_UD2 Reply: RSP\_UD
- Change primary address: SND\_UD Reply: ACK
- Reset RS1: SND\_UD Reply: ACK
- Slave selection for the secondary address Reply: ACK

- The device does not reply to unknown requests

- The transfer rate is detected automatically

- The device has a voltage monitor. In case of voltage loss, all registers are saved in the EEPROM.

### Changing the M-bus primary address:

To change the M-bus primary address, hold down SELECT for 3 s. In the menu that appears, press MODE to increment the address by 10. Press SELECT to increment by 1. When the required primary address is set, wait until the main menu reappears.

### Secondary address

- It is possible to communicate with the energy meters according to the standard EN13757 using the secondary address.

- The use of wild cards is possible.

For details refer to the operating instructions at [www.eltako.com](http://www.eltako.com).

### Important!

Before working on the current transformers disconnect the voltage paths of the energy meters.

Technical data page 26.

<b>DSZ15WDM-3x5A</b>	CT operated three-phase energy meter, MID approval	EAN 4010312501665	<b>217,90 €/pc.</b>
----------------------	--	-------------------	---------------------



**Typical connection**

4-wire-connection 3x230/400 V

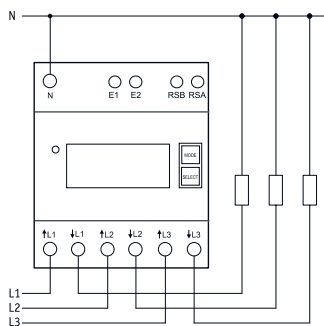

Technical data page 26.

# DSZ14DRS-3X80A MID



**RS485 bus wireless three-phase energy meter. Maximum current 3x80 A. Standby loss 0.8 W at L1 and only 0.5 W at L2 and L3 each.**

Modular device for DIN-EN 60715 TH35 rail mounting in distribution cabinets with IP51 protection class. 4 modules = 70 mm wide and 58 mm deep. Accuracy class B (1%). With RS485 interface.

It measures active energy by means of the current between input and output. The internal power consumption of 0.8 W or 0.5 W active power per path is neither metered nor indicated.

**1, 2 or 3 phase conductors with max. currents up to 80 A can be connected.**

The inrush current is 40 mA.

The terminals I1 and N must always be connected.

**Connection to the Eltako RS485 bus via a FBA14 by means of a 2-wire screened bus line (e.g. telephone line).** The meter reading and the momentary capacity are transferred to the bus – e.g. for transfer to an external computer of the GFVS 4.0 Software – and is also transferred to the wireless network via the FAM14. For this it is necessary that a device address is assigned from the wireless antenna module FAM14, according to the operating instructions.

Also display with FEA65D.

**The 7 segment LC display is also legible twice within a period of 2 weeks without power supply.**

The power consumption is displayed with a LED flashing 1000 times per kWh next to the display.

**Designed as standard for using as double-tariff meter:** Switch over to a second tariff by applying 230 V to terminals E1/E2.

On the right next to the display are the keys MODE and SELECT. Press them to scroll through the menu according to the operation manual. First the **background lighting** switches on. The display then shows the total active energy per tariff, the active energy per resettable memory RS1 or RS2, and the instantaneous values of consumption, voltage and current per phase.

**Error message (false)**

When the phase conductor is missing or the current direction is wrong 'false' and the corresponding phase conductor are indicated on the display.

<b>DSZ14DRS-3x80A</b>	RS485 bus wireless three-phase energy meter, MID approval	EAN 4010312501733	<b>170,00 €/pc.</b>
-----------------------	---	-------------------	---------------------



**Typical connection**

4-wire-connection 3x230/400 V

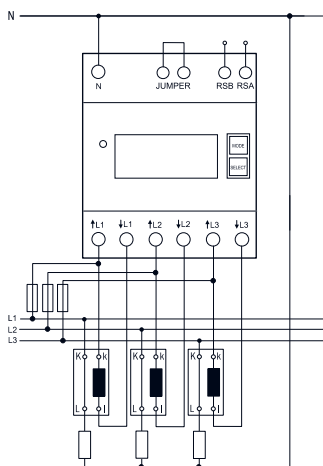

Technical data page 26.

## DSZ14WDRS-3X5A MID

MID

**RS485 bus wireless three-phase energy meter with settable CT ratio and MID. Maximum current 3x5 A. Standby loss 0.8 W at L1 and only 0.5 W at L2 and L3 each.**

Modular device for DIN-EN 60715 TH35 rail mounting in distribution cabinets with IP51 protection class. 4 modules = 70 mm wide and 58 mm deep. Accuracy class B (1%). With RS485 interface. This three-phase energy meter measures active energy by means of the current between input and output. The internal power consumption of 0.8 W or 0.5 W active power per path is neither metered nor indicated.

**1, 2 or 3 phase conductors with max. currents up to 5 A can be connected.**

The inrush current is 10 mA.

The terminals #L1 and N must always be connected.

**Connection to the Eltako RS485 bus via a FBA14 by means of a 2-wire screened bus line (e.g. telephone line).** The meter reading and the momentary capacity are transferred to the bus – e.g. for transfer to an external computer of the GFVS 4.0 Software – and is also transferred to the wireless network via the FAM14. For this it is necessary that a device address is assigned from the wireless antenna module FAM14, according to the operating instructions.

Also display with FEA65D.

**The 7 segment LC display is also legible twice within a period of 2 weeks without power supply.**

The power consumption is displayed with a LED flashing 10 times per kWh next to the display.

On the right next to the display are the keys MODE and SELECT. Press them to scroll through the menu.

First the **background lighting** switches on. The display then shows the total active energy, the active energy of the resettable memory as well as the instantaneous values of consumption, voltage and current per phase

**The CT ratio can also be set.** It is set to 5:5 at the factory and blocked with a bridge over the terminals which are marked with 'JUMPER'. To adjust the CT ratio to the installed transformer remove the bridge and reset the energy meter according to the operation manual. Then block it again with the bridge. Adjustable current transformer ratios: 5:5, 50:5, 100:5, 150:5, 200:5, 250:5, 300:5, 400:5, 500:5, 600:5, 750:5, 1000:5, 1250:5 and 1500:5.

**Error message (false)**

When the phase conductor is missing or the current direction is wrong 'false' and the corresponding phase conductor are indicated on the display.

**Important!** Before working on the current transformers disconnect the voltage paths of the energy meters.

<b>DSZ14WDRS-3x5A</b>	RS485 bus wireless three-phase energy meter, MID approval	EAN 4010312501450	<b>177,20 €/pc.</b>
-----------------------	---	-------------------	---------------------

## RS485 BUS WIRELESS SINGLE-PHASE ENERGY METER FWZ14-65A



N	N
←	→
BUS	
↑L	↓L

# FWZ14-65A

**RS485 bus wireless single-phase energy meter, maximum current 65 A. Only 0.5 watt standby loss.**

Modular device for DIN-EN 60715 TH35 rail mounting. 1 module = 18 mm wide, 58 mm deep. Accuracy class B (1%). With RS485 interface.

**Connection to the Eltako-RS485 bus. Bus cross wiring and power supply with jumper.**

The meter reading, the current power and the serial number will be handed over to the bus – eg for forwarding to an external computer, the software GFVS 4.0 or GFVS-Energy – and also to the wireless network via FAM14. For this it is necessary that a device address is assigned from the wireless antenna module FAM14, according to the manual.

Also display with FEA65D.

It measures active energy by means of the current between input and output. The internal power consumption of 0.5 watt active power is not metered.

Like all meters without declaration of conformity (e.g. MID), this meter is not permitted for billing.

1 phase conductor with a max. current up to 65 A can be connected.

The inrush current is 40 mA. In operation the rotary switch must be set to AUTO.

Power consumption is indicated using a LED.

If the L input and the L output were interchanged when hooked up, a normal rate (HT)/off-peak (NT) switchover telegram is transmitted to indicate the hook-up error.

If the anticipated load exceeds 50%, maintain an air gap of ½ pitch unit to the devices mounted adjacently. Thereto included are 2 spacers DS14, a short jumper and two long jumpers.

<b>FWZ14-65A</b>	RS485 bus wireless single-phase energy meter	EAN 4010312501511	<b>65,70 €/pc.</b>
------------------	--	-------------------	--------------------





Further settings can be made using the PC Tool PCT14.

## F3Z14D



**Wireless meter concentrator for electricity, gas and water meters.  
For 3 S0 interfaces and/or 3 AFZ scanners, only 0.1 watt standby loss.**

Modular device for DIN-EN 60715 TH35 rail mounting. 1 modul = 18 mm wide, 58 mm deep.

**Connection to the Eltako-RS485 bus. Bus cross wiring and power supply with jumper.**

This meter concentrator concentrates the data of up to three electricity, data and water meters and supplies this data to the RS485 bus. Either for forwarding to an external computer or for sending over the Wireless Building System.

Hook-up is either by connection to the S0 interface of the meters or by use of an AFZ scanner on each Ferraris meter. The scanner is bonded above the rotary disc of the meter and connected by its connecting wire to one of the S01-S03/GND terminals. The F3Z14D detects automatically whether an S0 interface or an AFZ is connected.

The meter reading is entered into the display by two pushbuttons as well as the impulse rate (number of impulses or revolutions per kilowatt hour or cubic meter). The settings can be locked.

Meter readings can be entered and read out using the **PCT14 PC Tool**. In addition, impulse rates can be entered. The default display is selectable and operation of the device is interlocked.

The display is subdivided into 3 fields.

### Field 1:

The default display is the unit of the meter reading currently displayed in Field 3, either in kilowatt hours kWh or megawatt hours MWh or cubic meter M3 or cubic decametre DM3

### Field 2:

Momentary value of active power in watts and kilowatts or flow in centilitres and decilitres.

The arrow on the left in display field 1 indicates automatic switchover from 0-99 W or cl/s to 0.1 to 65 kW or dal/s. The display depends on the number of impulses of the meter.

The displayed minimum load is e.g. 10 watts at 2000 impulses per KWH and 2000 watts at 10 impulses per KWH.

### Field 3:

The meter reading is the default display. Every 4 seconds, the display alternates between 3 integer numbers and 1 decimal point (from 0 to 999.9) and an additional 1 or to 3 integer numbers (from 0 to 999).

### Select meter in display:

Press MODE and then press MODE again to select the **ANZ function**. Press SET to select the meter number to be displayed as default. Press MODE to confirm.

**Issue device address in the bus and send teach-in telegrams** as described in the operating instructions.

**All Eltako energy meters are fitted with an S0 interface and can therefore be connected to the energy meter concentrator F3Z14D. Only devices FWZ14-65A, DSZ14DRS-3x80A and DSZ14WDRS-3x5A are directly connected to the bus.**

<b>F3Z14D</b>	RS485 bus meter collector	EAN 4010312501528	<b>52,90 €/pc.</b>
---------------	---------------------------	-------------------	--------------------

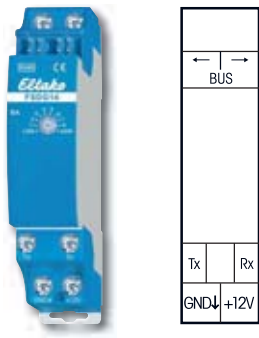

**Function rotary switch**

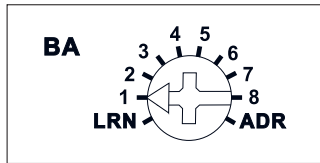

Standard setting ex works.



IR scanner for energy meters

# FSDG14



**Wireless energy meter data gateway for meters equipped with an IEC 62056-21 IR interface. 2 channels. Only 0.4 watt standby loss.**

Modular device for DIN-EN 60715 TH35 rail mounting. 1 module = 18 mm wide, 58 mm deep.

**Connection to the Eltako-RS485 bus. Bus cross wiring and power supply with jumper.**

This energy meter data gateway can provide the data of an electronic domestic supply meter (eHZ-EDL) with IR interface according to IEC 62056-21 and SML protocol version 1 to the RS485 bus. Either for forwarding to an external computer or the GFVS software.

Regular flashing of the **green LED** indicates that the FSDG14 is receiving data from the meter. Active power, up to 4 meter readings and the serial number are transferred. The serial number corresponds to the last 4 bytes (hex) of the server ID printed on the meter. The telegram is sent over the wireless building service by means of the wireless antenna module FAM14. Usage data are transmitted over channel 1 and delivery data over channel 2. It is therefore essential for the FAM14 to issue a device address. If there is a change in active power or a meter reading, the appropriate telegram is sent immediately and all telegrams including the serial number are sent cyclically every 10 minutes.

Also display with FEA65D.

The PCT14 PC tool can also read out the FSDG14.

**Turn the rotary switch** to select the following operating modes (OBIS codes according to IEC 62056-61):

- 1: Usage meter (1.8.0) and usage power on channel 1, delivery meter (2.8.0) and delivery power on Channel 2.
- 2: Usage tariff 1(1.8.1) and tariff 2 (1.8.2) and usage power on channel 1, delivery tariff 1(2.8.1) and tariff 2 (2.8.2) and delivery power on channel 2.
- 3: Usage tariff 1(1.8.1) and tariff 2 (1.8.2) and usage power on channel 1, delivery meter (2.8.0) and delivery power on Channel 2.
- 4: Usage meter (1.8.0) and usage power on channel 1, delivery tariff 1(2.8.1) and tariff 2(2.8.2) and delivery power on channel 2.

The link is made by using an AIR IR scanner. The scanner is attached by its fixing magnets to the IR output of the meter and is connected by its connecting cable to terminals Rx, GND and +12 V.

<b>FSDG14</b>	RS485 bus energy meter data gateway	EAN 4010312316146	<b>47,90 €/pc.</b>
<b>AIR</b>	IR scanner for energy meters	EAN 4010312316153	<b>102,80 €/pc.</b>

**SINGLE-PHASE ENERGY METER WSZ15D-32A MID AND  
SINGLE-PHASE ENERGY METER WSZ15DE-32A, WITHOUT APPROVAL**

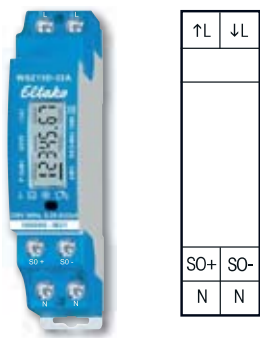

**Typical connection**

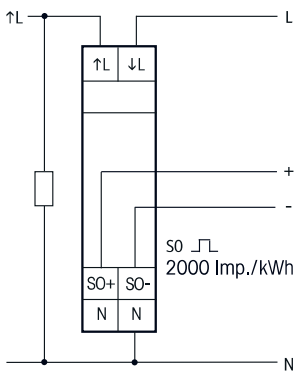

Technical data page 26.

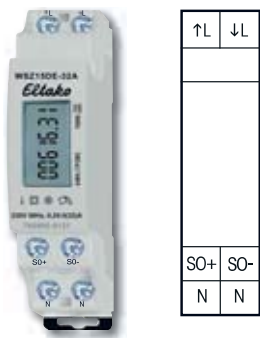

**Typical connection**

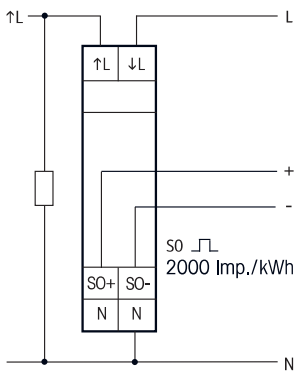

Technical data page 26.

## WSZ15D-32A MID

MID

**Maximum current 32 A. Standby loss 0.4 watt only.**

Modular device for DIN-EN 60715 TH35 rail mounting.  
1 module = 18 mm wide and 58 mm deep.  
Accuracy class B (1%). With SO interface.

This single-phase energy meter measures active energy by means of the current between input and output. The internal power consumption of 0.4 watt active power is neither metered nor indicated. 1 phase conductor with a max. current of up to 32 A can be connected.

The start current is 20 mA.

If the anticipated load exceeds 50%, maintain an air gap of 1/2 pitch unit to the devices mounted adjacently. If necessary, use spacer DS12.

Two N terminals for secure cross wiring of several counters.

**The 7 segment LC display is also legible twice within a period of 2 weeks without power supply.**

**Press the button.**

Below the displays is a button which you can use to browse through the menu as described in the User Manual. First the **background lighting** switches on. Then you can display the total active energy, active energy of the resettable memory and the instantaneous values for active power, voltage and current. Power consumption is shown by a bar flashing at a rate of 1000 times per kWh.

**Error message**

In the event of a connection error the backlighting of the display flashes.

<b>WSZ15D-32A</b>	Single-phase energy meter, MID approval	EAN 4010312501627	<b>59,90 €/pc.</b>
-------------------	---	-------------------	--------------------

## WSZ15DE-32A

**Maximum current 32 A. Standby loss 0.4 watt only.**

Modular device for DIN-EN 60715 TH35 rail mounting.  
1 module = 18 mm wide and 58 mm deep.  
Accuracy class B (1%). With SO interface.

It measures active energy by means of the current between input and output. The internal power consumption of 0.4 watt active power is neither metered nor indicated. Like all meters without declaration of conformity (e.g. MID), this meter is not permitted for billing.

**Every 30 seconds, the display switches for 5 seconds from the accumulated active energy in kWh to the momentary consumption in watts.**

1 phase conductor with a max. current up to 32 A can be connected. If the anticipated load exceeds 50%, maintain an air gap of 1/2 pitch unit to the devices mounted adjacently.

If necessary, use spacer DS12. The inrush current is 20 mA. The display can only be read when the power supply is on. However, the consumption is saved to a non-volatile memory and is displayed immediately after power restoration.

Two N terminals for secure cross wiring of several counters.

The digital display has 7 digits. Two decimal places are indicated up to 99999.99 kWh. Above 100000.0 kWh there is only one decimal place.

Power consumption is shown by a bar flashing at a rate of 1000 times per kWh.

**Error message**

In the event of a connection error a LED in the display flashes.

<b>WSZ15DE-32A</b>	Single-phase energy meter, without approval	EAN 4010312501702	<b>50,00 €/pc.</b>
--------------------	---	-------------------	--------------------



**Typical connection**

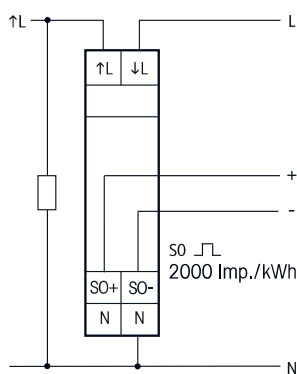

Technical data page 26.

# WSZ15D-65A MID



**Maximum current 65 A. Standby loss 0.4 watt only.**

Modular device for DIN-EN 60715 TH35 rail mounting.

1 module = 18 mm wide and 58 mm deep.

Accuracy class B (1%). With SO interface.

This single-phase energy meter measures active energy by means of the current between input and output. The internal power consumption of 0.4 watt active power is neither metered nor indicated.

1 phase conductor with a max. current up to 65 A can be connected.

The start current is 40 mA.

If the anticipated load exceeds 50%, maintain an air gap of 1/2 pitch unit to the devices mounted adjacently.

If necessary, use spacer DS12.

Two N terminals for secure cross wiring of several counters.

**The 7 segment LC display is also legible twice within a period of 2 weeks without power supply.**

**Press the button.**

Below the displays is a button which you can use to browse through the menu as described in the User Manual. First the **background lighting** switches on. Then you can display the total active energy, active energy of the resettable memory and the instantaneous values for active power, voltage and current.

Power consumption is shown by a bar flashing at a rate of 1000 times per kWh.

**Error message**

In the event of a connection error the backlighting of the display flashes.

<b>WSZ15D-65A</b>	Single-phase energy meter, MID approval	EAN 4010312501696	<b>71,50 €/pc.</b>
-------------------	---	-------------------	--------------------





**Typical connection**

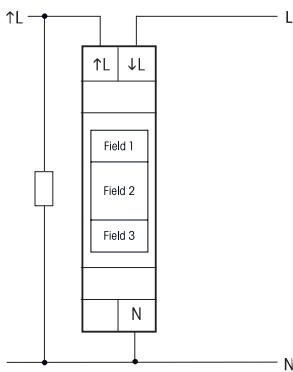

# WZR12-32A

**Maximum current 32 A, standby loss 0.5 watt only.**

Modular device for DIN-EN 60715 TH35 rail mounting.  
1 module = 18 mm wide, 58 mm deep.

**This single-phase energy meter with reset function uses the current between input and output to measure active energy and saves the consumption parameter in a non-volatile memory.**

Like all meters without declaration of conformity (e.g. MID), this meter is not permitted for billing. Accuracy conforms to Class B MID (1%) like all Eltako single-phase energy meters, the inrush current is 20 mA.

The display is subdivided into 3 fields.

**Field 1:**

This display refers to the cumulative value in field 3.

**|||| moving slowly to the right** = Field 3 shows the cumulative consumption since last reset. This is the display standard mode.

**H01** = Field 3 shows the consumption for the last hour up to H24 = 24 hours ago.

**D01** = Field 3 shows the consumption for the last day up to D95 = 95 days ago.

**Field 2:**

Instantaneous values of energy consumption (active power) in watt (W) or kilowatt (kW).

The display arrows on the left and right show the automatic change W and kW.

**Field 3:**

Cumulative value up to 9999 kWh. Display up to 9.999 kWh with 3 decimal digits, from 10 kWh with 1 decimal digit and from 1000 kWh without decimal digit.

**Press the left button MODE** to scroll down the display options which are shown in field 1:

H01 and D01 as described above. Finally, press MODE to show the abbreviation of the set language, e.g. GB for English, D for German, F for French and ES for Spanish.

**Press the right button SELECT** once within the display options to increment the indicated figure by 1.

The corresponding value is indicated in field 3. The last clock hour then becomes the hour before last, etc. If the active language was selected with MODE, press SELECT to switch to a different language. Exit the new language setting by pressing MODE to activate the setting.

The program returns to the standard display mode automatically if MODE or SELECT are not operated for 20 seconds or if you press both buttons briefly simultaneously.

**Reset**

**Hold down the buttons MODE and SELECT simultaneously for 3 seconds until RES appears in segment 1. Then press SELECT briefly to reset all memories. Afterwards the program returns automatically to standard display mode.**

Technical data page 26.

<b>WZR12-32A</b>	Single-phase energy meter with reset, without approval	EAN 4010312501252	<b>60,00 €/pc.</b>
------------------	--	-------------------	--------------------

## MOBILE SINGLE-PHASE ENERGY METERS – THE VERSATILE QUICK PLUG-IN SOLUTION

With increasing electrical energy costs coupled with increasing requirements it is becoming more and more important to know the exact costs and use of energy more than ever before. Inside a building this can be accomplished by fixed meters, but what about outside? From charging your car battery to temporary lighting rigs,

temporary drying machines or outside catering wagons, energy used has a cost and an accurate bill is much better than an estimate for both parties. Eltako presents the quick and easy solution for your temporary single phase MID metering needs with its robust design and easy to read display, which can be used again and again.



### WSZ110DSS-16A MID

NEW MID

**Mobile single-phase energy meter with German type plug and coupling (Type F).  
Suitable for indoor and outdoor use. Maximum current 16 A, Standby loss 0,4 watt only.**

Housing dimensions 110x70x35 mm, connection cable 1.5 m (including plug and coupling).  
Accuracy class B (1%).

This mobile single-phase energy meter measures active energy by means of the current between input and output. The internal power consumption of 0.4 watt active power is neither metered nor indicated.

**Every 30 seconds, the display switches for 5 seconds from the accumulated active energy in kWh to the momentary consumption in watts.**

The start current is 20 mA.

The display can only be read when the power supply is on. However, the consumption is saved to a non-volatile memory and is displayed immediately after a power failure.

The digital display has 7 digits.

Two decimal places are indicated up to 99999.99 kWh.

Above 100000.0 kWh there is only one decimal place.

Power consumption is shown by a LED flashing at a rate of 2000 times per kWh.

Technical data page 26.

WSZ110DSS-16A	Mobile single-phase energy meter with MID	EAN 4010312501795	88,50 €/pc.
---------------	---	-------------------	-------------



## WSZ110DSS-16A+PRCD MID

NEW MID

**Mobile single-phase energy meter with German type plug and coupling (Type F).  
With additional residual current circuit breaker PRCD 30 mA. Suitable for indoor and outdoor use.  
Maximum current 16 A. Standby loss 0.4 watt only.**

Housing dimensions 110x70x35 mm, connection cable 1.5 m (including plug and coupling).  
Accuracy class B (1%).

This mobile single-phase energy meter measures active energy by means of the current between input and output. The internal power consumption of 0.4 watt active power is neither metered nor indicated.

**Every 30 seconds, the display switches for 5 seconds from the accumulated active energy in kWh to the momentary consumption in watts.**

The start current is 20 mA.

The display can only be read when the power supply is on. However, the consumption is saved to a non-volatile memory and is displayed immediately after a power failure.

The digital display has 7 digits.

Two decimal places are indicated up to 99999.99 kWh.

Above 100000.0 kWh there is only one decimal place.

Power consumption is shown by a LED flashing at a rate of 2000 times per kWh.

**The personal protection intermediate switch PRCD** detects fault currents that occur, for example, when a faulty electrical device is touched, and interrupts the current so quickly that life-threatening accidents can be prevented. It also has an undervoltage release that switches off in the event of a mains voltage failure. With function indication and test button.

<b>WSZ110DSS-16A+PRCD</b>	Mobile single-phase energy meter personal protection intermediate switch PRCD, with MID	EAN 4010312501832	<b>174,80 €/pc.</b>
---------------------------	---	-------------------	---------------------



## WSZ110CEE-16A MID

NEW MID

**Mobile single-phase energy meter with CEE plug and CEE coupling. Suitable for indoor and outdoor use.  
Maximum current 16 A. Standby loss 0,4 watt only.**

Housing dimensions 110x70x35 mm, connection cable 1.5 m (including plug and coupling).  
Accuracy class B (1%).

This mobile single-phase energy meter measures active energy by means of the current between input and output. The internal power consumption of 0.4 watt active power is neither metered nor indicated.

**Every 30 seconds, the display switches for 5 seconds from the accumulated active energy in kWh to the momentary consumption in watts.**

The start current is 20 mA.

The display can only be read when the power supply is on. However, the consumption is saved to a non-volatile memory and is displayed immediately after a power failure.

The digital display has 7 digits.

Two decimal places are indicated up to 99999.99 kWh.

Above 100000.0 kWh there is only one decimal place.

Power consumption is shown by a LED flashing at a rate of 2000 times per kWh.

<b>WSZ110CEE-16A</b>	Mobile single-phase energy meter with MID	EAN 4010312501801	<b>89,30 €/pc.</b>
----------------------	---	-------------------	--------------------

Technical data page 26.

**MOBILE SINGLE-PHASE ENERGY METER WSZ110CEE-16A+PRCD MID**  
**MOBILE THREE-PHASE ENERGY METER DSZ180CEE-32A MID**



## WSZ110CEE-16A+PRCD MID

**NEW** **MID**

**Mobile single-phase energy meter with CEE plug and CEE coupling.**  
**With additional residual current circuit breaker PRCD 30 mA. Suitable for indoor and outdoor use.**  
**Maximum current 16 A. Standby loss 0,4 watt only.**

Housing dimensions 110x70x35 mm, connection cable 1.5 m (including plug and coupling).  
 Accuracy class B (1%).

This mobile single-phase energy meter measures active energy by means of the current between input and output. The internal power consumption of 0.4 watt active power is neither metered nor indicated.

**Every 30 seconds, the display switches for 5 seconds from the accumulated active energy in kWh to the momentary consumption in watts.**

The start current is 20 mA.

The display can only be read when the power supply is on. However, the consumption is saved to a non-volatile memory and is displayed immediately after a power failure.

The digital display has 7 digits.

Two decimal places are indicated up to 99999.99 kWh.

Above 100000.0 kWh there is only one decimal place.

Power consumption is shown by a LED flashing at a rate of 2000 times per kWh.

**The personal protection intermediate switch PRCD** detects fault currents that occur, for example, when a faulty electrical device is touched, and interrupts the current so quickly that life-threatening accidents can be prevented. It also has an undervoltage release that switches off in the event of a mains voltage failure. With function indication and test button.

<b>WSZ110CEE-16A+PRCD</b>	Mobile single-phase energy meter personal protection intermediate switch PRCD, with MID	EAN 4010312501856	<b>171,50 €/pc.</b>
---------------------------	---	-------------------	---------------------



## DSZ180CEE-32A MID

**NEW** **MID**

**Mobile three-phase energy meter with CEE plug 32 A and CEE coupling 32 A. Suitable for indoor and outdoor use. Maximum current 32 A, standby loss 0.5 watt per path only.**

Housing dimensions 180x86x82 mm, connection cable 1.5 m (including plug and coupling).  
 Accuracy class B (1%).

This mobile three-phase energy meter measures active energy by means of the current between input and output.

The internal power consumption of max. 0.5 watt active power per path is neither metered nor indicated.  
 The inrush current is 40 mA.

The display can only be read when the power supply is on. However, the consumption is saved to a non-volatile memory and is displayed immediately after a power failure.

The digital display has 7 digits. Two decimal places are indicated up to 99999.99 kWh.

Above 100000.0 kWh there is only one decimal place.

Power consumption is shown by a LED flashing at a rate of 100 times per kWh.

<b>DSZ180CEE-32A</b>	Mobile three-phase energy meter, with MID	EAN 4010312501825	<b>183,30 €/pc.</b>
----------------------	---	-------------------	---------------------

Technical data page 26.



## WIRELESS VISUALISATION AND CONTROL SOFTWARE GFVS-ENERGY AND WIRELESS ENERGY METER TRANSMITTER MODULE FSS12-12V DC

With the Wireless Visualisation and Control Software GFVS-Energy and the USB receiver FAM-USB, the wireless telegrams of the wireless energy meter transmitter module FSS12 or the single- and three-phase energy meters and the transmitter modules can be received or displayed on the PC.

⚠ Caution! The software GFVS-Energy is contained in the Wireless Visualisation and Control Software GFVS 4.0 and need not be installed separately.



with FAM-USB



## GFVS-Energy

**Wireless Visualisation and Control Software for up to 100 electricity meters with S0 interface with FSS12 energy meter transmitter modules as well as wireless single-phase energy meter, wireless three-phase energy meter and wireless energy meter transmitter modules.**

The software GFVS 4.0 on the Smart Home central unit SafeIV can evaluate up to 250 energy meters. **The wireless receiver FAM-USB** with USB port is required for PC reception and if required for transmitting wireless telegrams from a PC to load shedding relay and is not included in the scope of supply. It must be licenced via web.

<b>FAM-USB</b>	Wireless USB receiver/transmitter	EAN 4010312312971	<b>84,80 €/pc.</b>
----------------	-----------------------------------	-------------------	--------------------

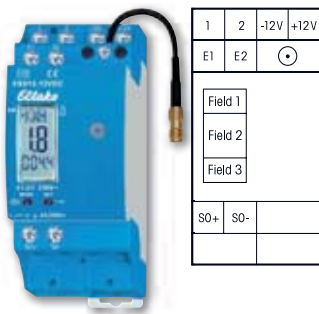

1	2	-12V	+12V
E1	E2		⤵
Field 1			
Field 2			
Field 3			
S0+	S0-		

## FSS12-12V DC

**Wireless energy meter transmitter module for connection to S0 interface of many single-phase energy meters and three-phase energy meters. Only 0.5 watt standby loss. With load shedding relay 1 NO contact potential free 4 A/250 V. With exchangeable antenna. If required, a wireless antenna FA250 can be connected.**

Modular device for DIN-EN 60715 TH35 rail mounting. 2 modules = 36 mm wide, 58 mm deep.

**The energy meter transmitter module FSS12 evaluates the signals from the energy meter S0 interface and transmits wireless telegrams containing consumption and meter reading to the Eltako wireless network for evaluation on a PC using the Visualisation and Control Software GFVS 4.0 and GFVS-Energy. On three-phase energy meters, the data sent includes normal rate (HT) or off-peak (NT) energy tariff data, provided the E1/E2 terminals on the three-phase energy meter are connected to E1/E2 on the FSS12. With adjustable pulse rate.**

GFVS-Energy supports up to 100 transmitter modules and GFVS 4.0 up to 250 transmitter modules.

The 12 V DC supply voltage is powered at 12 W by a switch mode power supply unit FSNT12-12V that is only 1 pitch unit wide. If the relay of the FSS12 is switched on, a power of 0.6 watts is required.

The setting and display screen is subdivided into 3 fields:

- **Field 1:** The normal display is the unit of the meter reading currently displayed in Field 3. This alternates every 4 seconds with either kilowatt hours kWh (KWH in display) or megawatt hours MWh (MWH in display). The display in Field 1 is supplemented by a + sign after the reading to indicate that the off-peak tariff rate is applied to E1/E2.
- **Field 2:** Instantaneous values of energy consumption (active power) in watt (W) or kilowatt (kW). The left-pointing arrow in Field 1 indicates an automatic switchover from 0 to 99 W to 0.1 to 65 kW.
- **Field 3:** The meter reading is the normal display. Every 4 seconds the display alternates between 3 whole numbers and 1 decimal point (from 0.1 to 999.9 kWh) and 1 or max. 3 whole numbers (from 0 to 999 MWh). The meter reading is displayed without decimals in increments of 1 kWh with freely chosen pulse rates whose last digit is not 0.

**Wireless telegrams:** Maximum every 130 seconds a performance telegram will be sent and the display will be updated. Otherwise a telegram will be sent within 20 seconds if the power changed by at least 10%.

A switchover from HT to NT is transmitted immediately in the same way as a meter reading change. A full telegram comprising meter reading HT, meter reading NT and power is transmitted 20 seconds after the power supply is switched on and then every 10 minutes. The LED lights up briefly when a telegram is transmitted.

For settings with the buttons MODE and SET see the operating instructions.

<b>FSS12-12V DC</b>	Wireless energy meter transmitter module	EAN 4010312301944	<b>92,30 €/pc.</b>
---------------------	--	-------------------	--------------------

The enclosed small antenna can be replaced with a wireless antenna FA250 with magnetic base and cable.

### Typical connection

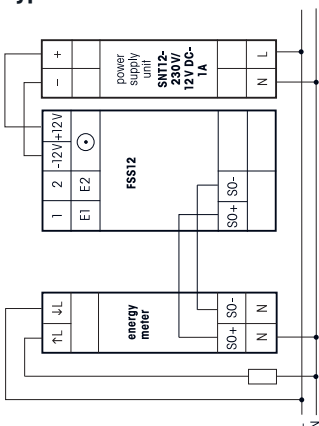



## FEA65D-wg

**Wireless energy consumption indicator with display for individual fitting and mounting into the E-Design65 switching system. For up to 20 wireless single-phase energy meters, wireless three-phase energy meters and energy meter transmitter modules. Illuminated display. Standby loss 0.2 watt only.**

Power supply 12 V DC. A 20 cm long red/black connecting wire is routed to the rear.

The complete module can be removed from the frame for screw mounting.

We recommend stainless-steel countersunk screws 2.9 x 25 mm, DIN 7982 C, for screw connections. Both with rawl plugs 5 x 25 mm and with 55 mm switch boxes. Set of 2 stainless-steel countersunk screws 2.9 x 25 mm and plugs 5 x 25 mm are enclosed.

The energy consumption indicator evaluates the information of the wireless two-phase energy meters FWZ12 and FWZ61, the RS485 two-phase energy meter transmitter module FWZ14-65A, the RS485 three-phase energy meters DSZ14DRS and DSZ14WDRS as well as the wireless energy meter transmitter module FSS12.

The last energy meter selected is displayed from EM01 to EM20: the accumulated energy consumption (meter reading) in KWh with 7 digits, of which one digit is a decimal point, and the currently consumed active power (momentary capacity) from 15 watts to 65,000 watts.

The data of one energy meter transmitter module FSS12 and one RS485 three-phase energy meter DSZ14DRS also contains separate values for normal rate (HT) and off-peak (NT), both of which are displayed. Momentary capacity is also identified accordingly.

When you press MODE for longer than two seconds, the display goes to energy meter EM01.

For energy meter EM01, an additional statistic can be displayed for total energy consumption over the last hours, days, months and years. This is obtainable by briefly pressing MODE, *statistic* appears in the display.

Press MODE to browse through all the possible displays *consump. total, hour, day, month and year*.

**Press the button SET** within the display options. Each press of the button increments the number displayed by 1 and the actual value is indicated in the display. The last full hour then becomes the last hour but one, etc.

Hour 01 = Displays consumption over the last full hour to 24 = 24 hours ago.

Day 01 = Displays consumption of the last full day up to day 31 = 31 days ago.

Month 01 = Displays consumption of the last full month up to month 12 = 12 months ago.

Year 01 = Displays consumption of the last full year up to year 24 = 24 years ago.

20 seconds after last pressing MODE or SET, and if you press and hold down MODE for longer than 2 seconds, the program revert automatically back to normal display.

<b>FEA65D-wg</b>	Wireless energy consumption indicator with display, pure white glossy	EAN 4010312315903	<b>100,20 €/pc.</b>
------------------	---	-------------------	---------------------

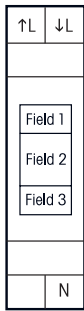

**Typical connection**

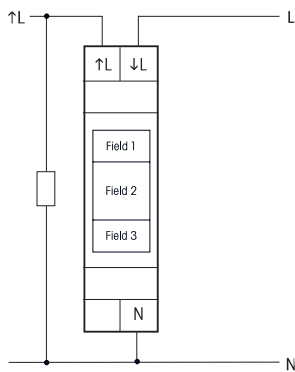

# EVA12-32A

**Maximum current 32 A, standby loss 0.5 watt only.**

Modular device for DIN-EN 60715 TH35 rail mounting.  
1 module = 18 mm wide, 58 mm deep.

**The energy consumption indicator EVA12 uses the current between input and output to measure active energy in the same way as a single-phase energy meter. It saves the consumption parameter in a non-volatile memory.**

Like all meters without declaration of conformity (e.g. MID), this meter is not permitted for billing. Accuracy conforms to Class B MID (1%) like all Eltako single-phase energy meters. The inrush current is 20 mA.

**In this way the energy consumption indicator reproduces exactly the reading on the billing energy meter installed at a different location in the building.**

The display is subdivided into 3 fields.

■ **Field 1:**

This display refers to the cumulative value in field 3.

**||| moving slowly to the right** = Field 3 shows the cumulative consumption since last reset. This is the display standard mode.

**H01** = Field 3 shows the consumption for the last hour up to H24 = 24 hours ago.

**D01** = Field 3 shows the consumption for the last day up to D31 = 31 days ago.

**M01** = Field 3 shows the consumption for the last month up to M12 = 12 months ago.

**Y01** = Field 3 shows the consumption for the last year up to Y24 = 24 years ago.

■ **Field 2:**

Instantaneous values of energy consumption (active power) in watt (W) or kilowatt (kW). The display arrows on the left and right show the automatic change W and kW.

■ **Field 3:**

Cumulative value in kWh. Display up to 9.999 kWh with 3 decimal digits, from 10 kWh with 1 decimal digit and from 1000 kWh without decimal digit.

**Press the left button MODE** to scroll down the display options which are shown in field 1:

H01, D01, M01 and Y01 as described above. Finally, press MODE to show the abbreviation of the set language, e.g. GB for English, D for German and F for French.

**Press the right button SELECT** once within the display options to increment the indicated figure by 1. The corresponding value is indicated in field 3. The last clock hour then becomes the hour before last, etc. If the active language was selected with MODE, press SELECT to switch to a different language. Exit the new language setting by pressing MODE to activate the setting.

The program returns to the standard display mode automatically if MODE or SELECT are not operated for 20 seconds or if you press both buttons briefly simultaneously.

**Reset**

To start saving the values to the nearest hour, we recommend performing a reset at an opportune moment after installation. Hold down the buttons MODE and SELECT simultaneously for a further 3 seconds until RES appears in field 1. Then press SELECT briefly to reset all memories. Afterwards the program returns automatically to standard display mode.

Technical data page 26.

<b>EVA12-32A</b>	Single-phase energy meter with energy consumption indicator	EAN 4010312500828	<b>63,60 €/pc.</b>
------------------	---	-------------------	--------------------

## WIRELESS SINGLE-PHASE ENERGY METER FWZ12-65A



↑L	↓L
N	N

# FWZ12-65A

**Wireless single-phase energy meter, maximum current 65 A. Only 0.5 watt standby loss.**

Modular device for DIN-EN 60715 TH35 rail mounting. 1 module = 18 mm wide, 58 mm deep.

This single-phase energy meter measures active energy by means of the current between input and output and transmits the current power and meter reading over the Eltako wireless network. Accuracy class B (1%).

**Evaluation on the computer with Eltako Wireless Building Visualisation and Control Software GFVS or with energy consumption indicator FEA65D.**

GFVS-Energy supports up to 100 transmitter modules and GFVS 4.0 up to 250 transmitter modules.

The internal power consumption of max. 0.5 watt active power is not metered.

Like all meters without declaration of conformity (e.g. MID), this meter is not permitted for billing.

1 phase conductor with a max. current up to 65 A can be connected.

If the anticipated load exceeds 50%, maintain an air gap of ½ pitch unit to the devices mounted adjacently. If necessary, use spacer DS12.

The inrush current is 40 mA. The consumption is saved to a non-volatile memory and is immediately available again after a power failure.

**Wireless telegrams:** A telegram is transmitted within 60 seconds if the power status changes by min. 10 percent. A change in meter reading is transmitted immediately. A full telegram comprising meter reading and power status is transmitted every 10 minutes. When the power supply is switched on, a **teach-in telegram** is sent to teach in the associated energy consumption indicator.

If the L input and the L output were interchanged when hooked up, a normal rate (HT)/off-peak (NT) switchover telegram is transmitted to indicate the hook-up error.

<b>FWZ12-65A</b>	Wireless single-phase energy meter	EAN 4010312311059	<b>88,30 €/pc.</b>
------------------	------------------------------------	-------------------	--------------------

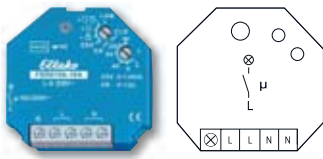

**Typical connection**

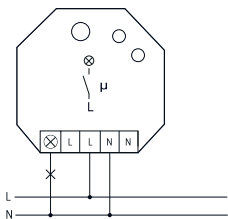

## FSR61VA-10A



**1 NO contact not potential free 10 A/250 V AC, incandescent lamps up to 2000 watts, off delay with switch-off early warning and switchable pushbutton permanent light. With integrated current measurement up to 10 A. Encrypted wireless, bidirectional wireless and repeater function are switchable. Only 0.8 watt standby loss.**

For installation. 45 mm long, 45 mm wide, 33 mm deep. Supply voltage and control voltage 230 V. If a power failure occurs, the switching state is retained. If a power failure occurs repeatedly, the device is switched off in a defined sequence. After installation, wait for short automatic synchronisation before the switched consumer is connected to the mains. Apparent power is measured by the integrated current measurement from approx. 10 VA to 2300 VA when the contact is closed. A wireless telegram is transmitted into the Eltako wireless network within 30 seconds after switching on the load or after a change in power by min 5% and cyclically every 10 minutes.

**Evaluation on the computer with Eltako Wireless Building Visualisation and Control Software GFVS or with energy consumption indicator FEA65D.** GFVS-Energy supports up to 100 transmitter modules and GFVS 4.0 up to 250 transmitter modules. **You can teach in encrypted sensors.** You can switch on **bidirectional wireless** and/or a **repeater** function. Every change in state and incoming central command telegrams are confirmed by a wireless telegram. This wireless telegram can be taught-in in other actuators, in the GFVS software and in universal displays.

<b>FSR61VA-10A</b>	Wireless actuator Impulse switch with integr. relay function with current measurement	EAN 4010312311462	<b>86,90 €</b> /pc.
--------------------	---	-------------------	---------------------



## FSVA-230V-10A

**1 NO contact not potential free 10 A/250 V AC, incandescent lamps up to 2000 watts, ESL and LED up to 400 W. With integrated current measurement up to 10 A. Encrypted wireless, bidirectional wireless and repeater function are switchable. Only 0.8 watt standby loss.**

Adapter for German fused safety socket. With increased shock protection. Supply and switching voltage 230 V. In case of failure of the supply voltage, the switching state is maintained. The recurrent supply voltage is disconnected in a definite sequence. After plugging wait for short automatic synchronization before the switched consumer is plugged.

**This wireless actuator features state-of-the-art hybrid technology that we developed: we combined the wear-free receiver and evaluation electronics and a bistable relay.**

Apparent power is measured by the integrated current measurement from approx. 10 VA to 2300 VA when the contact is closed. A wireless telegram is transmitted into the Eltako wireless network within 30 seconds after switching on the load or after a change in power by min 5% and cyclically every 10 minutes.

**Evaluation on the computer with Eltako Wireless Building Visualisation and Control Software GFVS or with the energy consumption indicator FEA65D.** GFVS-Energy supports up to 100 energy meters and GFVS 4.0 up to 250 energy meters. **You can teach in encrypted sensors.** You can switch on **bidirectional wireless** and/or a **repeater** function. Every change in state and incoming central command telegrams are then confirmed by a wireless telegram. This wireless telegram can be taught into other actuators, the software GFVS 4.0, and universal displays. Up to 35 wireless pushbuttons are assigned **with the left button LRN**, either as a universal pushbutton, direction pushbutton or central pushbutton. For the control of extractor hoods or similar items up to 35 wireless window door contacts FTK or wireless window handle sensors FFG7B-rw can be taught-in. Several FTK or wireless window handle sensors FFG7B-rw are linked together. If a FTK or wireless window handle sensor FFG7B-rw is taught-in, control commands of eventually taught-in pushbuttons are no longer running. It can be switched on and off manually **with the right button**. **The LED** performs during the teach-in process according to the operation manual. It shows wireless control commands by short flickering during operation.

<b>FSVA-230V-10A</b>	Wireless actuator Socket switching actuator with current measurement	EAN 4010312314555	<b>112,40 €</b> /pc.
----------------------	--	-------------------	----------------------



## TECHNICAL DATA SINGLE-PHASE AND THREE-PHASE ENERGY METERS AND ENERGY CONSUMPTION INDICATOR

	EVA12-32A WSZ15D-32A WSZ15DE-32A WZR12-32A WSZ110	WSZ15D-65A	DSZ15D-3x80A DSZ15DE-3x80A DSZ15DM-3x80A DSZ14DRS-3x80A DSZ180CEE-32A	DSZ15WD-3x5A DSZ15WDM-3x5A DSZ14WDRS-3x5A
Rated voltage Extended range	230 V, 50 Hz -20%/+15%	230 V, 50 Hz -20%/+15%	3x230/400 V, 50 Hz -20%/+15%	3x230/400 V, 50 Hz -20%/+15%
Reference current $I_{ref}$ (Limiting current $I_{max}$ )	5(32)A WSZ110: Rated current 16A	10(65)A	3x10(80)A DSZ180: Rated current 32A	3x5(6)A
Internal consumption active power	0.4 W EVA12, WZR12: 0.5 W	0.4 W	0.5 W per path DSZ14DRS: 0.8 W at L1	0.5 W per path DSZ14WDRS: 0.8 W at L1
Display	LC display 7 digits, therefrom 1 or 2 digits after the decimal point	LC display 7 digits, therefrom 1 or 2 digits after the decimal point	LC display 7 digits, therefrom 1 or 2 digits after the decimal point	LC display 7 digits, therefrom 1 digit after the decimal point
Display instantaneous values	WSZ15D: With a key you can select active power, voltage and current WSZ15DE, WSZ110: Active power displayed for 5 seconds every 30 seconds EVA12, WZR12: active power	With a key you can select active power, voltage and current	With a key you can select total active energy and active energy resettable, power, voltage and current per phase tariff 1 and tariff 2 (not DSZ180)	With a key you can select total active energy and active energy resettable, power, voltage and current per phase
Accuracy class $\pm 1\%$	B	B	B	B
Inrush current according to accuracy class B	20 mA	40 mA	40 mA	10 mA
Operating temperature	-25/+55°C EVA12, WZR12: -10/+55°C	-25/+55°C	-25/+55°C	-25/+55°C
Interface (not DSZ180, EVA12, WZR12, WSZ110)	DSZ15DM and DSZ15WDM with M-bus interface. DSZ14DRS and DSZ14WDRS with interface for Eltako RS485 bus. All else: Pulse interface S0 according to DIN EN 62053-31, potential free by opto-coupler, max. 30 V DC/20 mA and min. 5 V DC. Impedance 100 ohms.			
	pulse length 30 ms	pulse length 30 ms	pulse length 30 ms	pulse length 30 ms
	2000 Imp./kWh	2000 Imp./kWh	1000 Imp./kWh	10 Imp./kWh
Terminal cover sealable	With sealing cap PK18. For the current path 1 sealing cap is required (not WSZ110)	With sealing cap PK18. For the current path 1 sealing cap is required	Terminal cover claps (not DSZ180)	Terminal cover claps
Protection degree	IP50 for mounting in distribution cabins with protection class IP51 WSZ110: IP54		DSZ180: IP54	
Maximum conductor cross section	6 mm <sup>2</sup> WSZ15D, WSZ15DE: L terminals 16 mm <sup>2</sup> (not WSZ110)	L terminals 16 mm <sup>2</sup> , N and S0 terminals 6 mm <sup>2</sup>	N and L terminals 16 mm <sup>2</sup> , S0, M-Bus and RS485 bus terminals 6 mm <sup>2</sup> DSZ15D/DE/DM-3x80A and DSZ14DRS-3x80A: L terminals 25 mm <sup>2</sup> (not DSZ180)	

**The N terminal of three-phase energy meters must be connected, if not the electronics might be destroyed.**

To comply with DIN VDE 0100-443 and DIN VDE 0100-534, a Type 1 or Type 2 surge protection device (SPD) must be installed.

# MEASURING INSTRUMENTS DIRECTIVE MID

On 31.04.2004, the European Parliament and the Council adopted the European Measuring Instruments Directive (MID) 2004/22/EC. The MID came into force in all member states of the EU and in Switzerland on 30.10.2006.

The 10 types of measuring instruments also include active electrical energy meters.

**The MID replaces previous regulations on national approval and subsequent calibration in the domestic, trade and light industry sectors.**

A manufacturer's Declaration of Conformity was produced based on this new directive.

There is a type examination certificate or pattern examination certificate for each type.

**The MID regulates the following:**

- the technical requirements (standard series DIN EN 50470-1/-3)
- the conformity assessment procedure
- the putting into use of measuring instruments
- marking the measuring instruments
- market surveillance

**National law continues to regulate the following:**

- recalibration
- calibration validity
- charges

When an MID instrument is put into use, we declare conformity with the MID in the operating instructions. The number of the type examination certificate is also quoted there.

## THE DEVICE BEARS THE MID CONFORMITY MARK THAT CONSISTS OF:

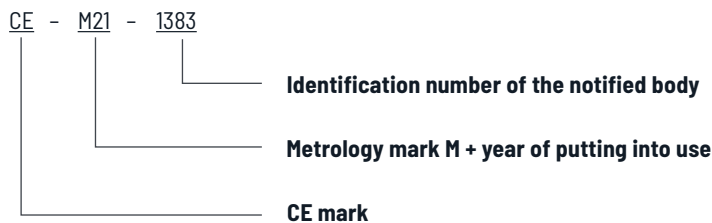

The year after the year of putting into use defines the recalibration time.

The period of calibration validity depends on the prevailing national law. In Germany, this is 8 years and can then be extended by a further 8 years by a state certified inspection body, i.e. not the manufacturer.

**MID meters require no subsequent calibration with calibration mark. Instead, they are the equivalent of calibrated meters as a result of MID testing and an EU Declaration of Conformity from the manufacturer.**

**Conventional installation**

Main meter 1 Main meter 2 Main meter 3

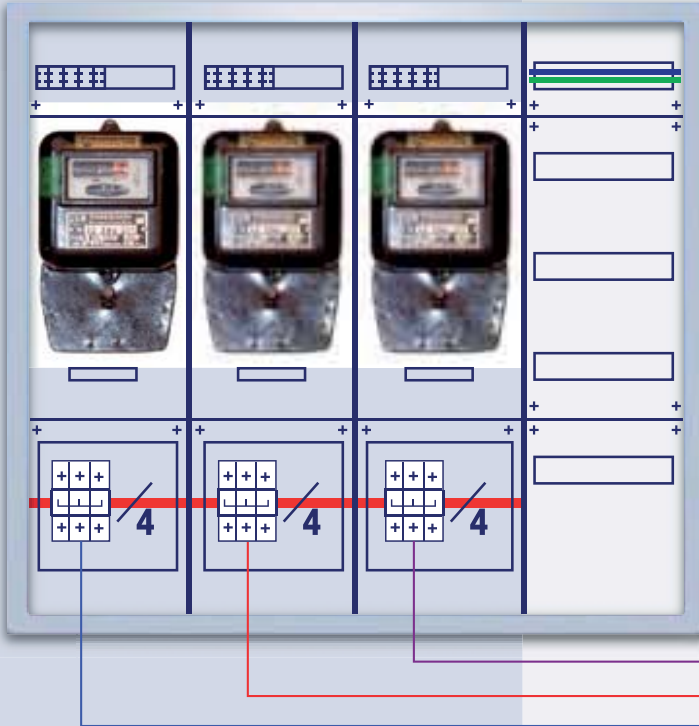

Power distribution panel in dwellings

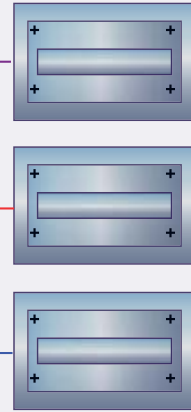

28

**Modern installation acc. to TAB 2007**

Main meter in meter cupboard

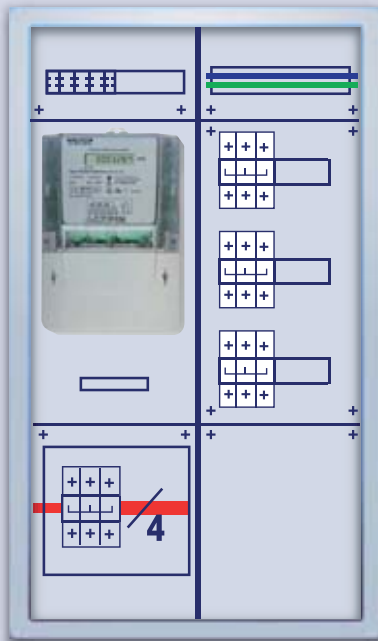

Dwelling meter with MID approval in power distribution

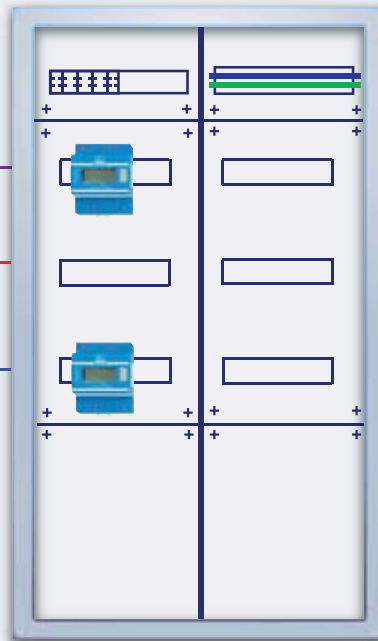

Dwelling meter with MID approval in power distribution panel directly in dwelling



(for example, in care homes)

TAB

VDE



**DO YOU HAVE ANY QUESTIONS?  
WE HAVE THE ANSWERS FOR YOU.**

